



GOLDRING
Lenco

INSTRUCTION MANUAL

“GL 70”

TRANSCRIPTION UNIT



INSTRUCTION MANUAL FOR GOLDRING -LENCO "GL 70" TRANSCRIPTION UNIT

It is recommended that these instructions be carefully read before unpacking the Unit.

DESCRIPTION

This precision engineered transcription unit is designed for monaural and stereophonic reproduction. It is fitted with the L.70 pick-up arm which has a detachable plug-in shell.

The turntable of the GL 70 unit is die-cast from zinc and copper alloy, and weighs 8 lbs. It is dynamically balanced and its lapped steel centre spindle runs in a cintered bronze bush with special thrust

pad to keep wow and flutter at less than 0.2%. The unique vertical drive system is used and this method allows the turntable speed to be continuously adjusted from above 80 r.p.m. to below 30 r.p.m. and from 15 to 18 r.p.m. Standard playing speeds, 78, 45, 33 $\frac{1}{3}$ and 16 r.p.m. are located by pre-set click-in positions.

A 4-pole constant velocity motor provides the drive for this unit and is specified to limit changes in turntable velocity to less than 1% for up to 13% changes in line voltage.

A pick-up lowering device is incorporated in this unit. This is coupled with the manual on/off switch, so that as the motor is turned on, the pick-up is automatically lowered. Similarly, as the motor is turned off the pick-up is raised from the record. The on/off switch is also coupled to the idler wheel disengagement arm, so that as the motor is turned off the idler wheel is automatically disengaged from both motor and turntable, thus preventing "flats" appearing on the idler wheel. The GL 70 is built to instrument standards of quality—a superb unit for the discriminating user.

SPECIFICATION

A.C. mains 200/250 V., 50 c.p.s.
4-pole constant velocity motor
(15 watts).

Continuously variable speed adjustment.

Positive click-in positions for 16, 33 $\frac{1}{3}$, 45 and 78 r.p.m.

8 lb. non-magnetic balanced turntable.

Centre spindle of ground and lapped steel in cintered bronze main bearing.

Wow and flutter—maximum 0.2%.

Rumble and hum—negligible.

Less than 1% speed change for 13% mains voltage change.

Positive drive and completely accurate speed control through the vertical drive system.

Pick-up arm—L.70.

Built-in pick-up lowering device.

Automatic disengagement of idler wheel.

DIMENSIONS

15 $\frac{1}{2}$ " long x 13 $\frac{1}{4}$ " wide x 5 $\frac{1}{2}$ " high.

Turntable diameter 12".

WARNING. The motor "U" is held in position by two screws "B" for safety in transit. Before the unit can be played these must be removed.

1. UNPACKING. This unit was carefully checked before leaving the factory. Observe the condition of the packing carton for signs of improper handling in transit. If damage is apparent make an immediate claim to the dealer from whom you made the purchase. Check that all items shown in paragraph 4 are complete.

2. BASEBOARD. The unit should be mounted on a wooden baseboard about $\frac{3}{8}$ "– $\frac{1}{2}$ " thick and of somewhat the same size as outlined on the enclosed template sheet.

The baseboard should be cut so as to provide one large cut-out, and drilled for four holes of 1" diameter.

The position of the cut-out and the holes may be obtained by either of these two methods:—

(a) Cover the baseboard with carbon paper laid face downwards and fix the template in the desired position with drawing pins at the given hole centres; then scribe on the heavy outline of the cut-out, so that the line is reproduced on the baseboard by the carbon paper.

(b) Attach template to the baseboard with self-adhesive tape or with pins, and prick through the template with a sharp pointed instrument such as a scriber or bradawl.

3. CABINET CLEARANCES. Top clearance: $2\frac{3}{4}$ " above top surface of wooden baseboard. Bottom clearance: $2\frac{1}{8}$ " below top surface of wooden baseboard.

4. CONTENTS OF CARTON. The following items are contained in the carton:—

- (a) The turntable packed.
- (b) Rubber turntable mat.
- (c) The motor unit complete with mounting plate.
- (d) Head shell "M" for pick-up arm.
- (e) Circular plastic moulding about $1\frac{1}{2}$ " in diameter. This is for use with those 45 r.p.m. records with $1\frac{1}{2}$ " centre holes. Place the moulding over the centre spindle and the 45 r.p.m. record will then fit.
- (f) An envelope containing the components for mounting the unit.
- (g) Groove locating arm.
- (h) Stroboscope.

5. MOUNTING MOTOR UNIT TO BASE-BOARD.

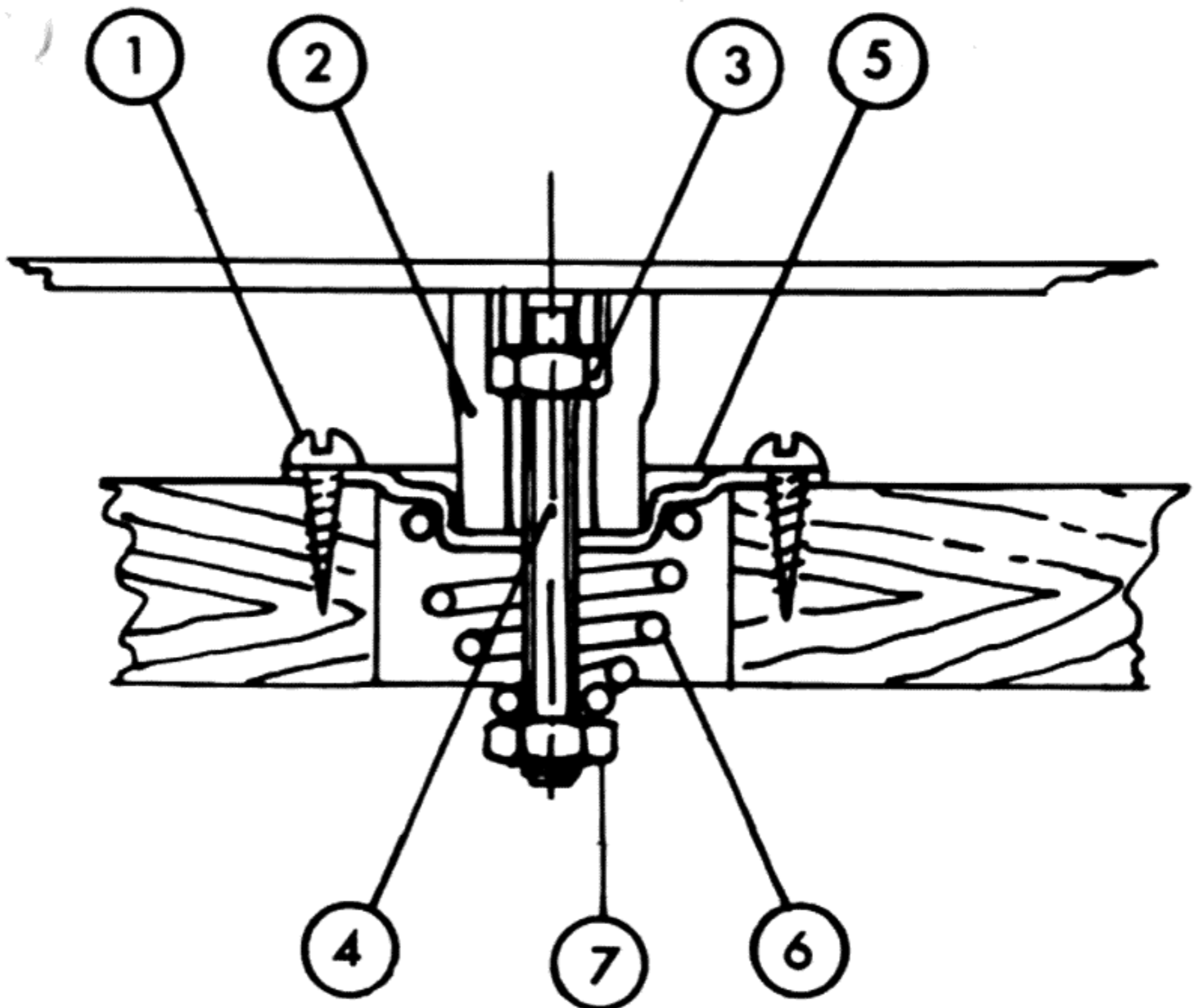

6. MOUNTING PROCEDURE. Screw the threaded spindle into tapped boss "V" underneath base plate, **having first removed from these bosses the grub screws.** Run the nylon nut up the spindle until it is tight against the boss. Screw the mounting plates on to the base board as shown on template. Push rubber bush over threaded spindle and lower unit on to motor mounting board so that the threaded spindles protrude through the mounting plates. Offer the springs to mounting plate and secure with lock nut. Levelling of unit is achieved by tightening or loosening this lock nut.

7. HEADSHELL. The headshell "M" of the L.70 arm is wired for stereo.

The red lead should be taken to the right-hand channel terminal of the cartridge—the green to the left-hand—the two black leads being taken to the common terminals.

When used for monaural the red lead and the black lead beneath it should be connected to the cartridge.

The leads from the pick-up arm are terminated in Phono plugs. These are standard and should fit the input of most amplifiers. The one colour coded red is the right-hand channel connection and should be plugged into the right-hand channel input of the amplifier. The one colour coded black is the left-hand channel and should be connected to the left-hand channel input of the amplifier.

To remove head shell, loosen knurled ring "L" on neck of shell and pull shell away from arm. When replacing head shell ensure that location pin in shell engages in slot in arm.

FIG. 1.

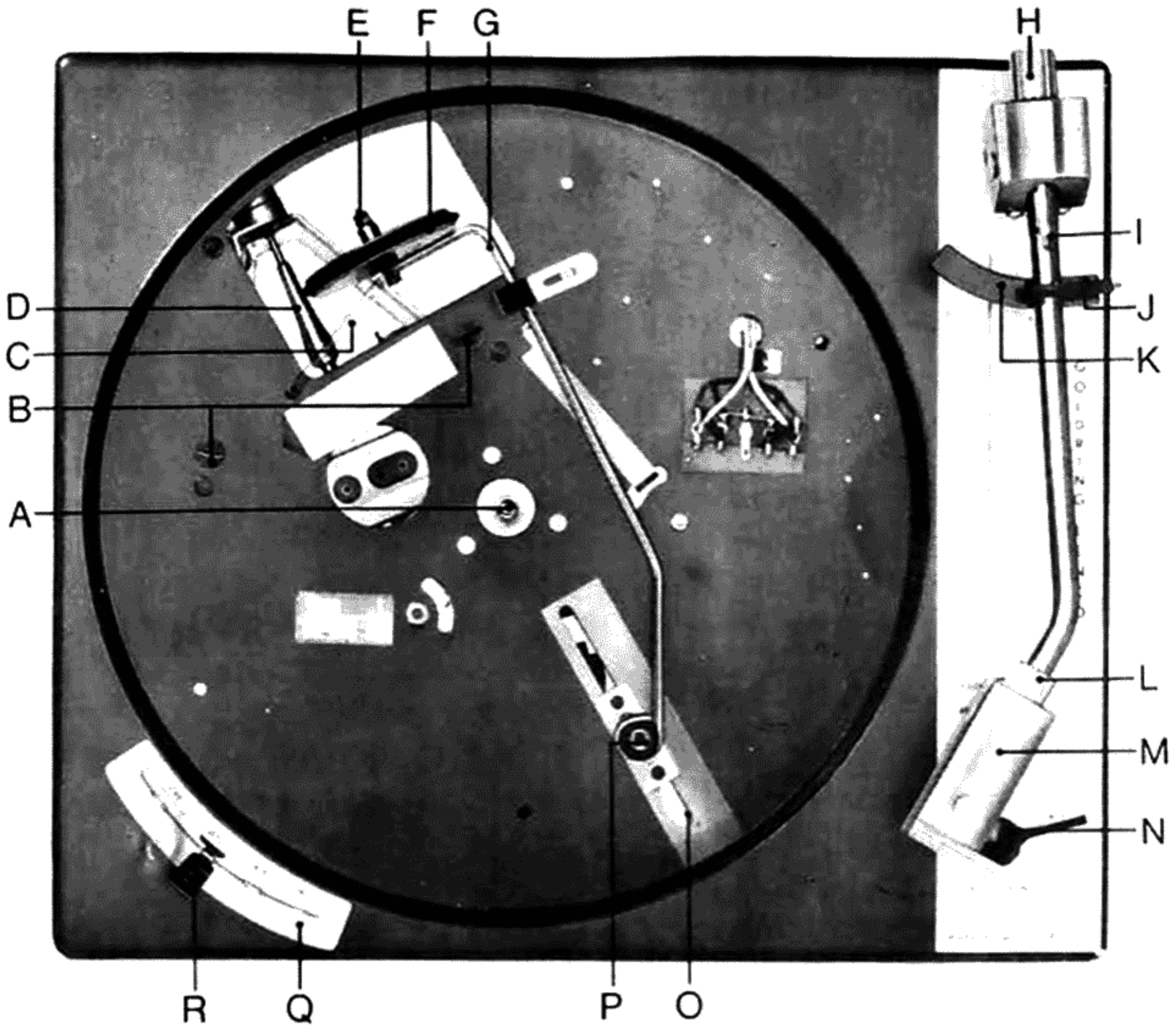

TRUE PLAN

- | | |
|---------------------------------------|---|
| TURNTABLE SPINDLE | A |
| TRANSIT SCREWS | B |
| IDLER WHEEL SPRING | C |
| MOTOR CONE | D |
| IDLER WHEEL LOCK NUTS | E |
| IDLER WHEEL..... | F |
| IDLER WHEEL ARM | G |
| STYLUS PRESSURE ADJUSTING SCREW | H |
| STYLUS PRESSURE GUIDE | I |
| ARM RETAINING CLIP | J |
| LOWERING ARM | K |
| HEADSHELL LOCKING RING | L |
| HEADSHELL | M |
| ON-OFF SWITCH LEVER | N |
| SLIDEWAY | O |
| IDLER WHEEL ARM CIRCLIP | P |
| SPEED ADJUSTING SCREW | Q |
| SPEED REGULATOR | R |

FIG. 2.

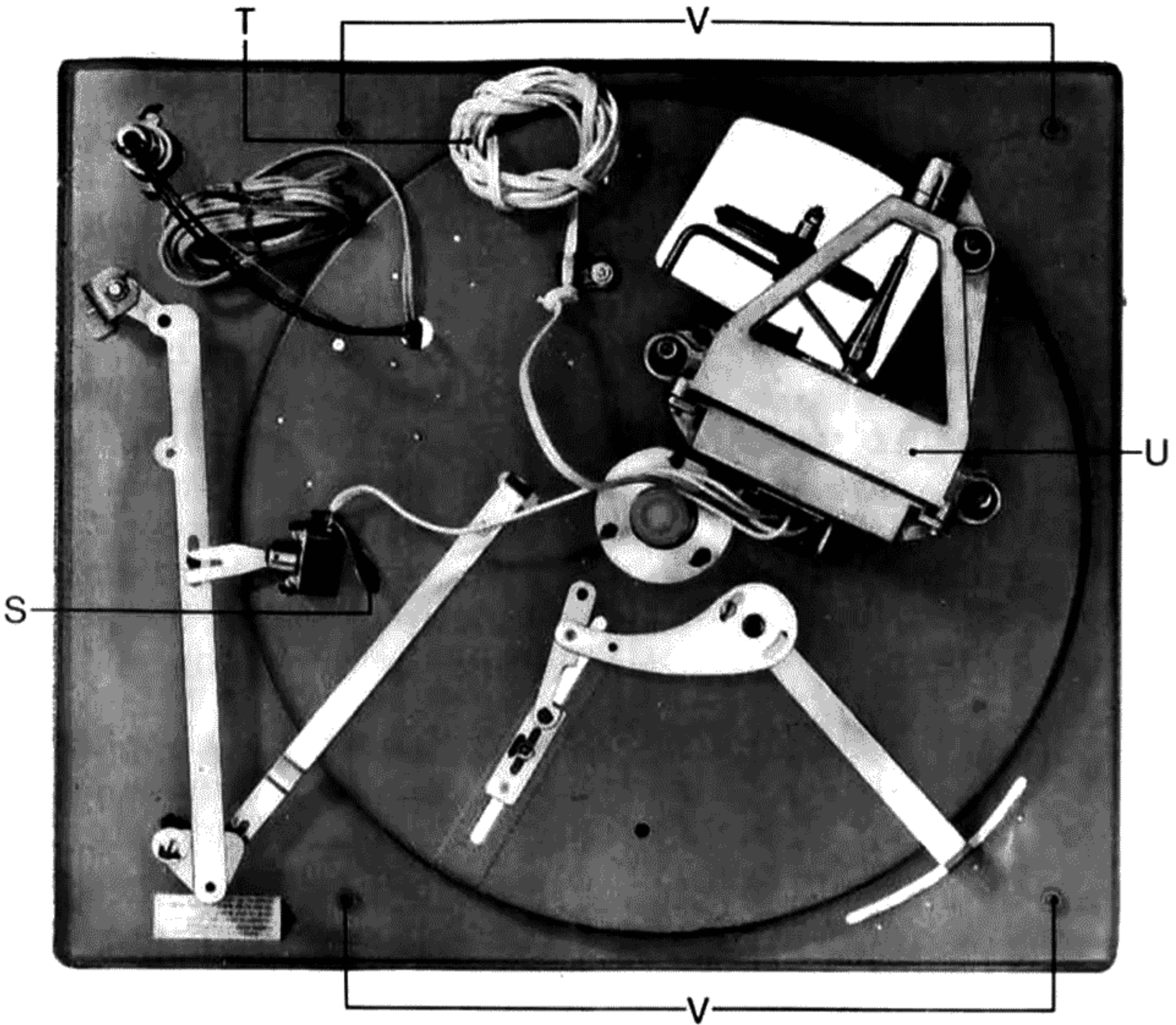

- UNDERSIDE PLAN**
- | | |
|-------------------------------|---|
| SWITCH CLICK SUPPRESSOR | S |
| MAINS LEAD | T |
| MOTOR | U |
| SPRING MOUNTING BOSSES | V |

8. PLAYING WEIGHT. Set the playing weight to the recommended value for the cartridge. To increase playing weight turn knurled knob "H" protruding at the rear of the arm clockwise. To reduce playing weight turn anti-clockwise. The calibration markings "I" on the arm *are not* an exact guide to stylus pressure. It is necessary to use a stylus pressure balance when initially setting the arm to the correct playing weight. A note should then be taken of the calibration on the arm. Should you wish to change the cartridge, then it is necessary to repeat the procedure, again using a stylus pressure balance. On changing back to the original cartridge it is only necessary to reset the arm according to the original calibration.

9. MAINS SUPPLY. The unit is normally supplied for 200/250 volts 50 cycles A.C. mains. Connect the mains lead "T" to your supply, ensuring that before this is done the unit is in the OFF position.

10. TURNTABLE. Place the turntable over the centre spindle "A", ensuring that it is properly seated. Place loose rubber mat over centre spindle. In order to remove the turntable apply a sharp tap with a wooden block to the centre spindle while lifting the turntable.

11. PICK-UP LOWERING ARM (K). This should be fitted to the spigot on the right-hand side of the base plate so that the lowering arm "K" points inwards. Place a record on the turntable and the pick-up on the record. Turn the On/Off switch "N" to the play position and adjust the height of the lowering arm until there is $\frac{1}{8}$ " clearance between it and the arm. Tighten the screw on the lowering arm and turn the switch to the OFF position. The pick-up should now be automatically lifted off the record.

The clip "J" on the lowering arm is for securing the pick-up arm. To disengage the pick-up from the clip move the pick-up towards the centre spindle and the clip will drop down out of the way.

The unit is now ready for playing.

12. TO PLAY. Check that the pick-up leads are correctly connected to the amplifier, that the mains lead is plugged in and the mains switched on. Check that the speed regulator is set for the correct speed for the record and that the correct stylus has been selected. Place the record on the turntable, position the pick-up on the locating arm above the desired passage of the record. Turn the On/Off switch "N" slowly in a clockwise direction and the motor will start. Continue turning slowly and the pick-up arm will automatically be lowered gently on to the record. At the end of the record or at the end of any passage you may choose, turn the switch anti-clockwise and the pick-up will be lifted off the record and the motor switched off.

13. SPEED ADJUSTMENTS. Although every care has been taken to ensure that the speed locations are pre-set accurately, it is possible that due to transit, or in mounting, these have become slightly

altered. Check each speed with the stroboscope which is supplied with the unit, and should adjustment be necessary this may be done by loosening the set-screw "Q" at the side of each speed catch, and adjusting the speed regulator "R" until the lines for the required speed on the stroboscope appear to remain stationary. The set-screw should then be tightened. Repeat this test at each speed.

N.B. That side of the stroboscope marked 50~ should be used in the United Kingdom. The stroboscope should be illuminated from an ordinary electric lamp operating on the appropriate A.C. mains supply whilst checking speeds. If this is not done the lines will not appear to remain stationary at any time.

14. IMPORTANT. Always switch off the motor before switching off at the mains.

15. MAINTENANCE AND SERVICE. The motor bearings and turntable spindle bearings are self-lubricating and no further lubrication should be necessary. Should the slideway "O" of the speed change mechanism run dry, then a small amount of vaseline should be applied. Care must always be taken that the underside of the turntable and the idler wheel be kept clean and free from grease.

IF the turntable does not rotate but the motor is going, then the idler wheel spring "C" needs replacing and the underside of the turntable should be cleaned with a solution of carbon-tetrachloride.

IF the motor does not operate when the unit is switched on, check that the mains are connected correctly. Should the motor still not operate, then a fault has developed and the motor should be repaired.

IF the motor continues to operate when the unit is switched off, then the switch click suppressing condenser "S" is faulty and should be replaced.

IF the speed is erratic or a rumble develops, then the idler wheel "F" should be cleaned with carbon-tetrachloride as should be the underside of the turntable and the motor cone "D".

IF a flat has developed on the idler wheel, this should be replaced. To replace idler wheel remove the circlip "P" and unhook the spring "C". Lift out the idler wheel arm "G". The idler wheel is secured by two locknuts "E". Undo these and slide the idler wheel off the spindle. Fit the new idler wheel, taking care not to touch the rubber ring. Do not over-tighten the locknuts. Replace assembly and refit spring and circlip.

Recommended cartridges for this Unit are:—

PICKERING V.15.AM1	Micro-magnetic stereo cartridge.
PICKERING V.15.AME1	Micro-Magnetic stereo cartridge fitted with elliptical diamond stylus.
PICKERING 380A	Moving magnet stereo cartridge.
GOLDRING CS.90	Ceramic Stereo cartridge.
GOLDRING CS.91/E	Ceramic stereo cartridge fitted with elliptical diamond stylus.
GOLDRING 580	Variable reluctance mono cartridge.
GOLDRING 600	Variable reluctance mono cartridge fitted with diamond stylus.

A Cabinet, Model C70 already cut out to accommodate this Unit is available. Of elegant design and finished in sapele mahogany, it comes complete with a clear perspex dust cover.